

MJE is the world's leading steel & engineering company.

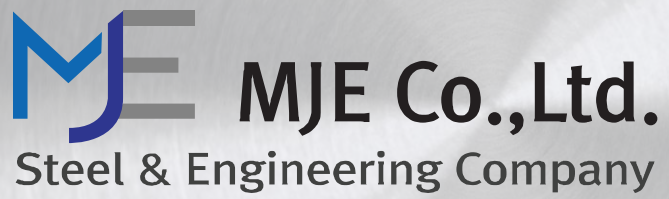



2

## Steel Manufacturing

- Line Building
- Revamping
- Smart Factory





## ■ This is MJE

Engineering for people,  
Engineering for change,  
Engineering for a better world.

## ■ PRODUCTS

MJE enhances customer value by developing innovative products and providing application technology



3

**MJE** MJE Co.,Ltd.  
Steel & Engineering Company



■ **MJE** realizes the improvement of customer value through innovative product development and utilization technology. To provide the world's best premium products and services, we will innovate R&D and take the lead in developing differentiated solutions and products.

## ■ GLOBAL NETWORK

MJE Global Network For  
Everyone, Everywhere



# CGL (Continuous Galvanizing Line)

## The Key Equipment to Produce Automobiles

The purpose of the Continuous Galvanizing Line (CGL) is to apply a coat of zinc onto the surface of steel coil in an effort to increase their corrosion resistance.

There is a wide range of zinc coat thickness controls, and the galvanized steel sheets are used for a broad range of purposes, including construction materials, automobiles and electrical appliances.

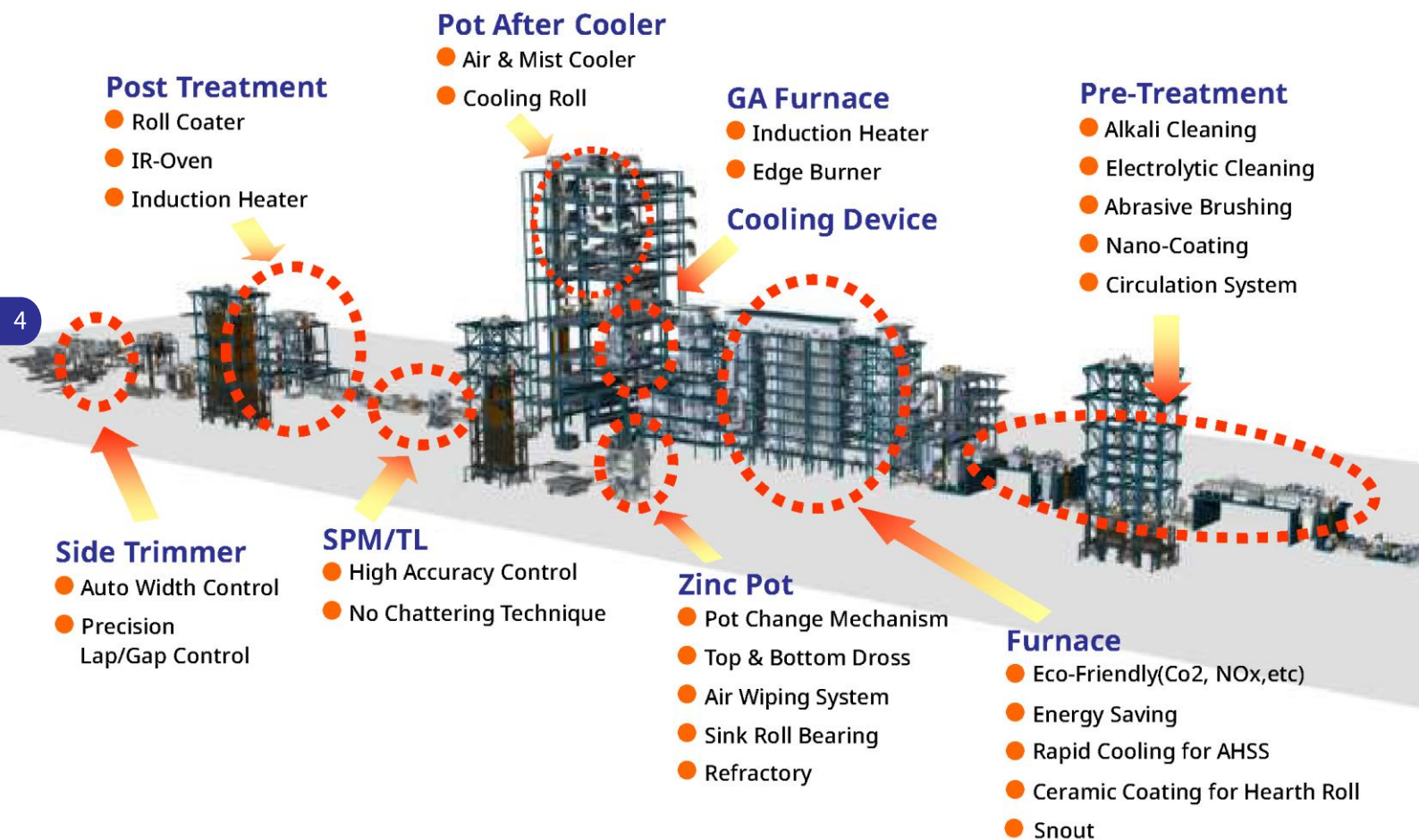

### Advanced Technologies

- Optimized Engineering with More than 30 Years Experience in Operation & Maintenance of Factory
- Patents for Engineering & Operation of CGL
- Specialized Engineering & Equipment with Operation Know-how
- ☞ Pre-Treatment, Furnace, POT, SPM, T/leveller etc

### Competitive price

- World-wide Global Sourcing Network
- Self-Implementation of Engineering for Specialized Equipment

### Smart Schedule & Management

- Standardized Engineering & Manufacturing Management Program
- Experienced Man-Power for Supervision with Maintenance & Operation

## CGL GA HEATER

### Control System

- Tension
- Speed
- Strip Tracking

### Welder

- Laser
- Overlap Seam

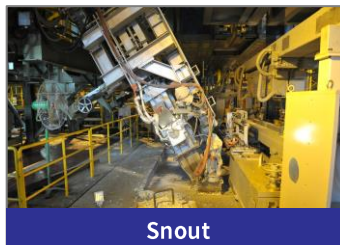
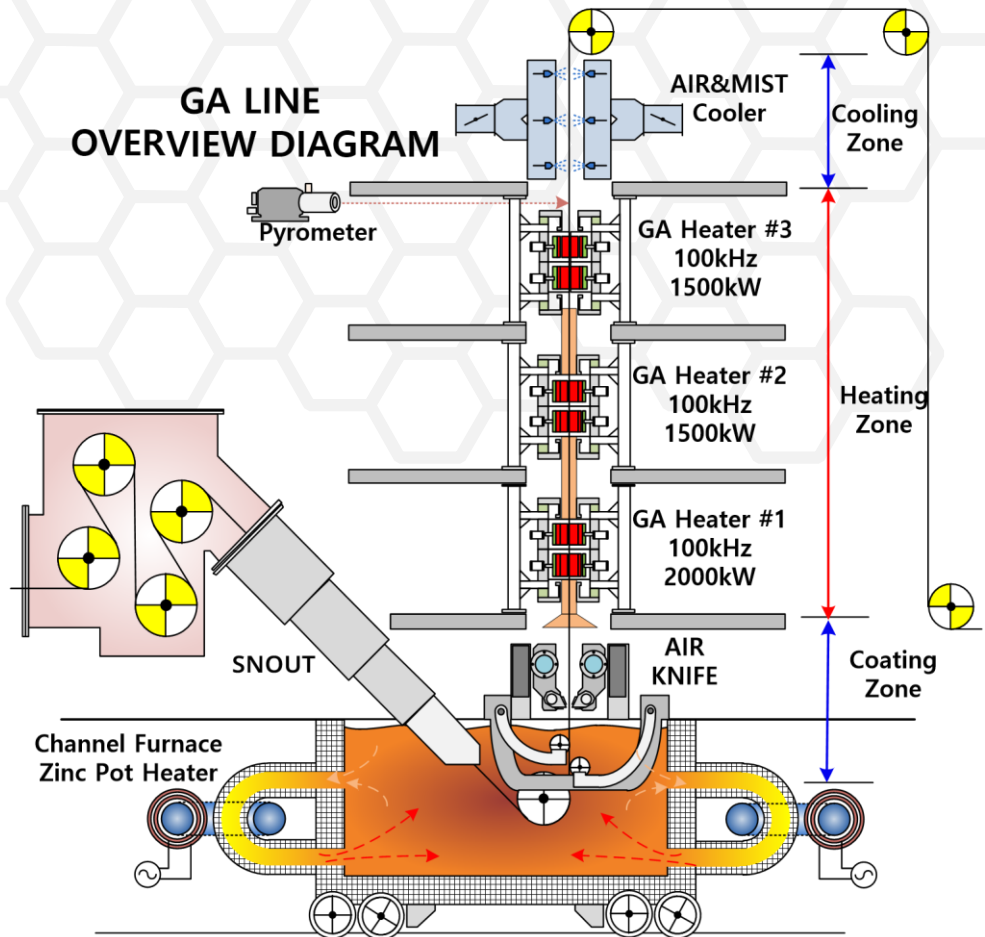
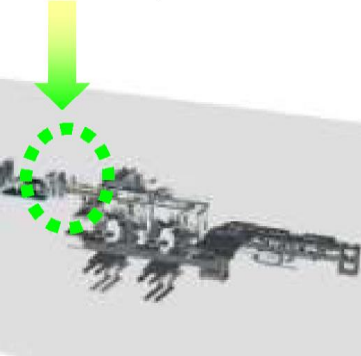

# CCL (Color Coating Line)



The color coating line signifies a process designed to put color coatings on both surfaces of an aimed metal strip according to the requirement from customers in the steel market.

This line consists of entry & exit section, pre-treatment section, coating section, electrical & control equipment and common facilities.

6

# PL (Packing Line)

## ► Coil Packing Line

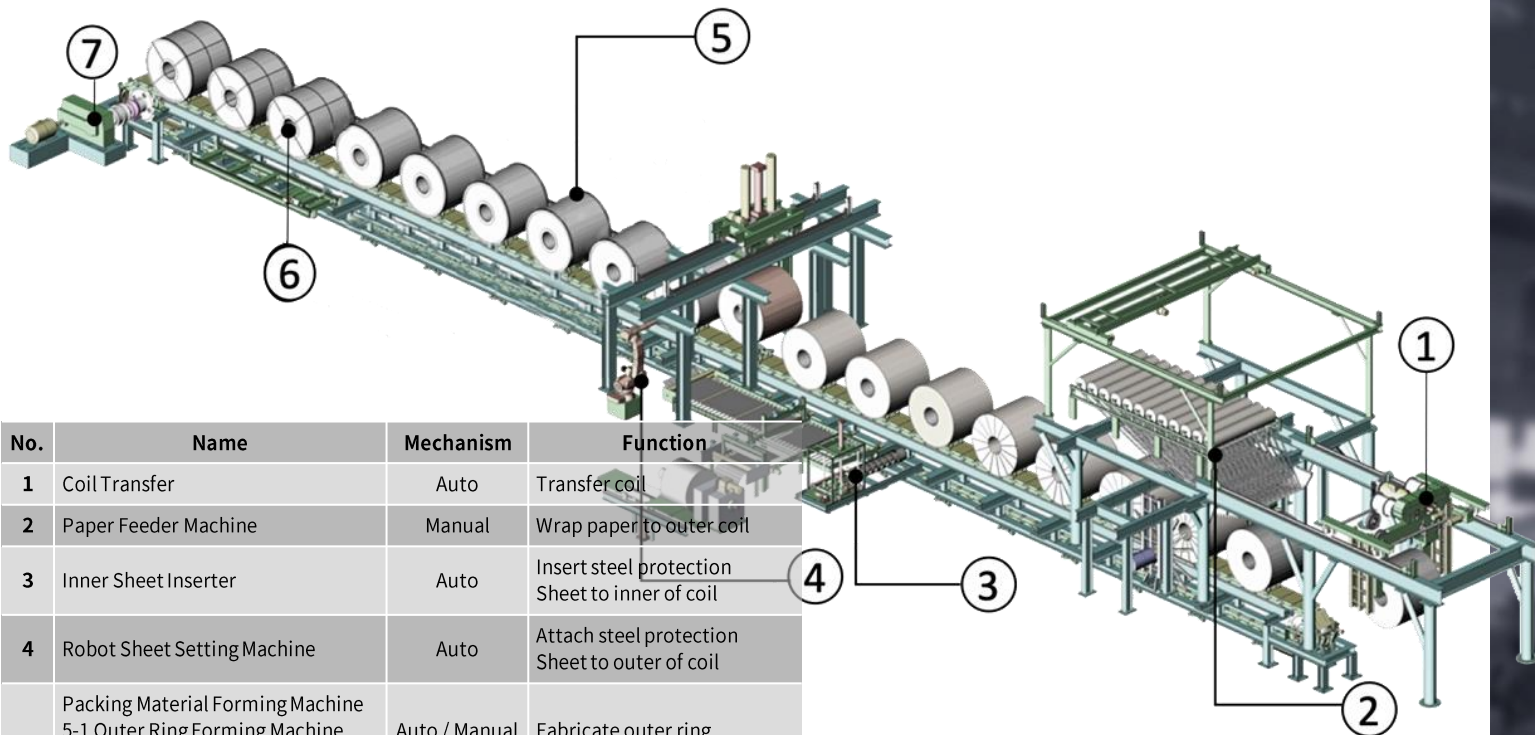

No.	Name	Mechanism	Function
1	Coil Transfer	Auto	Transfer coil
2	Paper Feeder Machine	Manual	Wrap paper to outer coil
3	Inner Sheet Inserter	Auto	Insert steel protection Sheet to inner of coil
4	Robot Sheet Setting Machine	Auto	Attach steel protection Sheet to outer of coil
5	Packing Material Forming Machine 5-1 Outer Ring Forming Machine 5-1 Inner Ring Forming Machine 5-3 Side Protector Forming Machine	Auto / Manual Auto / Manual Auto / Manual	Fabricate outer ring Fabricate inner ring Fabricate side protector
6	Steel Band Strapping Machine 6-1 Edge Strapping Machine 6-2 Eye Strapping Machine 6-3 Central Strapping Machine	Auto Auto Auto	Do edge strapping Do eye strapping Do central strapping
7	Chain Conveyor	Auto	Transport coil in packing line

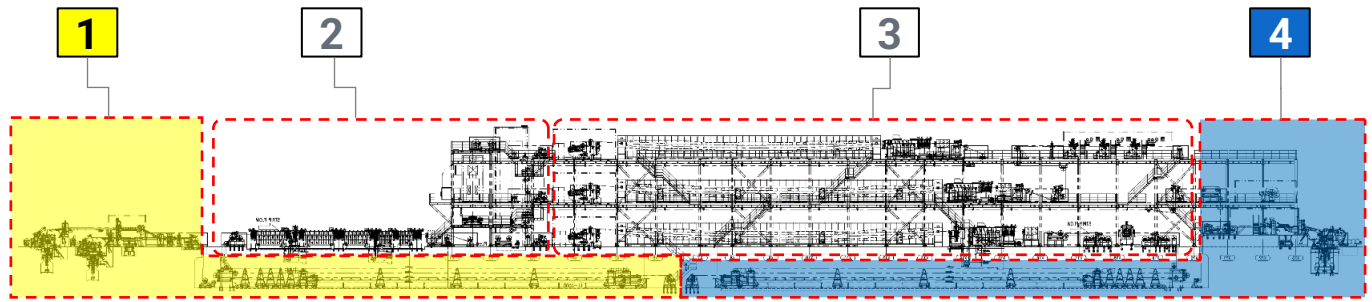

**1** Entry Section      **3** Coating Section      **\*\* R.T.O**  
**2** Pre-treatment Section      **4** Exit Section      (Regenerative Thermal Oxidizer)



Cleaning system

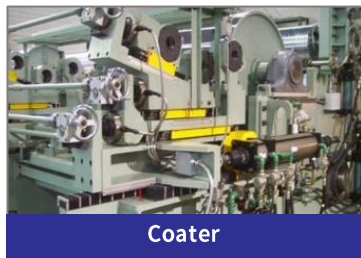

Coater



Printer



RTO

## Smart Strapping Head

### Characteristics

- It can maintain and control certain band binding forces with its servo motor control, depending on packaging.
- It allows precise control of the constant band overlap length, thereby reducing material costs.
- The operator can monitor the band binding force in real time with the load cell in the head.
- It has an automatic band-leveling function, equipped with a leveler on the band entrance (lower band available).
- It prevents the band surface from wheel marking, damage and chipping by applying a gear process to the band feed wheel side.
- It has a lightweight aluminum alloy body, so it is easy to disassemble and assemble.
- The new concept seal feeder applying the two-stage seal ejector system completely eliminates the cause of seal feeder trouble (seal type).
- The direction of the band binding spot welding point is set at a vertical way, thereby enhancing the welding force (Weld Type).

### Specifications

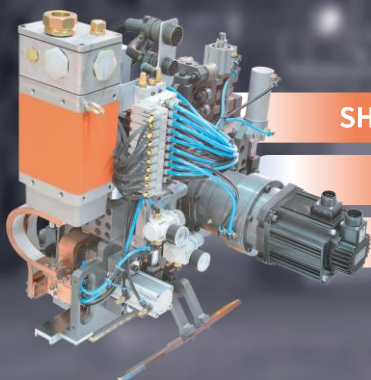

SH-32W

SH-25W

SH-19W

### Smart Strapping Head(Weld Type SH-32W)

Head Size : Weld Type – 583mm(w) X 597mm(l) X 625mm(h)

Strap Size : 32mm x Thick, 0.6 to 1.2mm. (Cold-Rolled Steel)

Motor Specification : Electric(Servo) Motor Control.

Feed & Take-up Speed : 0 to 2600mm/sec (Variable)

Final Tension Force : 50 to More than 2100kgf.

Joint Strength : About Min. 90%.

Head Weight : Weld Type – 125kg.

Weld Transformer : Weld Type – 32KVA, 440V, 5.6V, 60Hz.

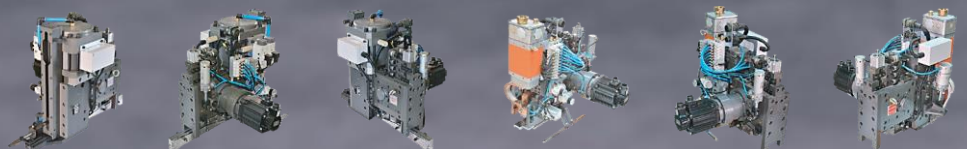

# Contact Type Strip Shape Measuring System

Power Shape Meter, PSM-2000



## System Configuration

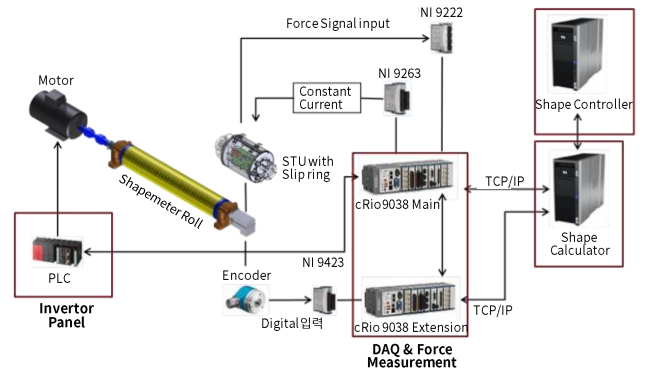
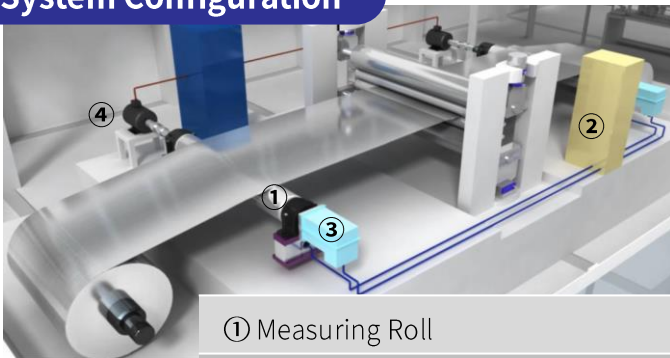

- |                                  |  |
|----------------------------------|--|
| ① Measuring Roll                 | Measuring strip force / force transducer(magnetic) installed |
| ② Shape DAQ & Calculator         | Data acquisition & shape calculation device                  |
| ③ STU                            | Power & sensor signal transfer device                        |
| ④ Synchronous motor & Controller | Strip speed synchronizing function's motor & controller      |

## Shape Measuring Roll

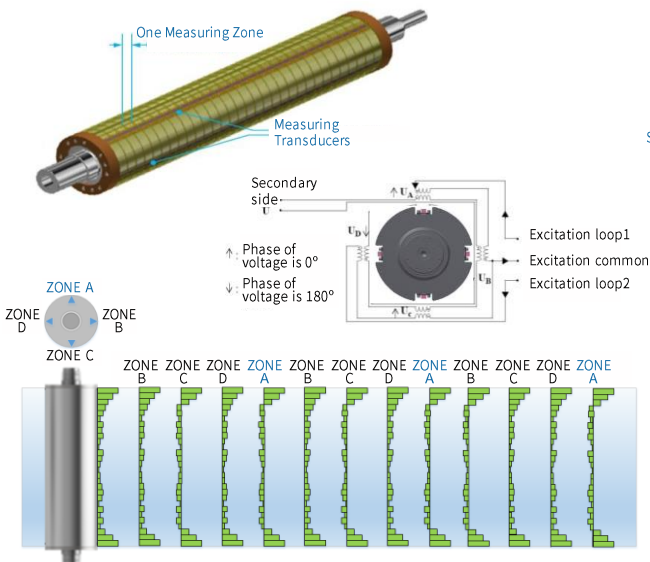

## Magnetic Load Cell

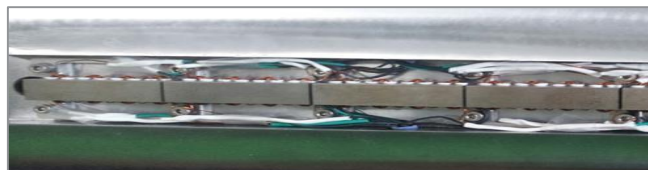
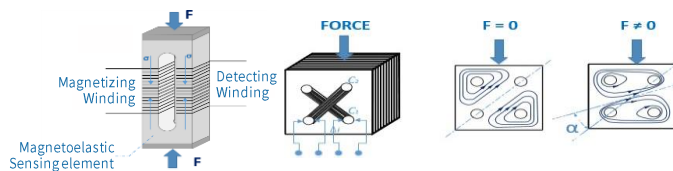



# Caster Strand Monitoring System

## ► Roll Checker

### MEASURED RESULTS DISPLAY

- MS Windows based software with graphical user Interface report.
- Measured results can be reported to MS Excel format file.

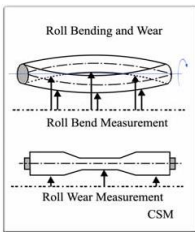
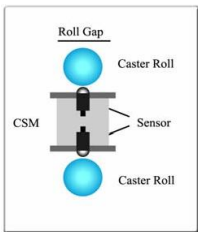
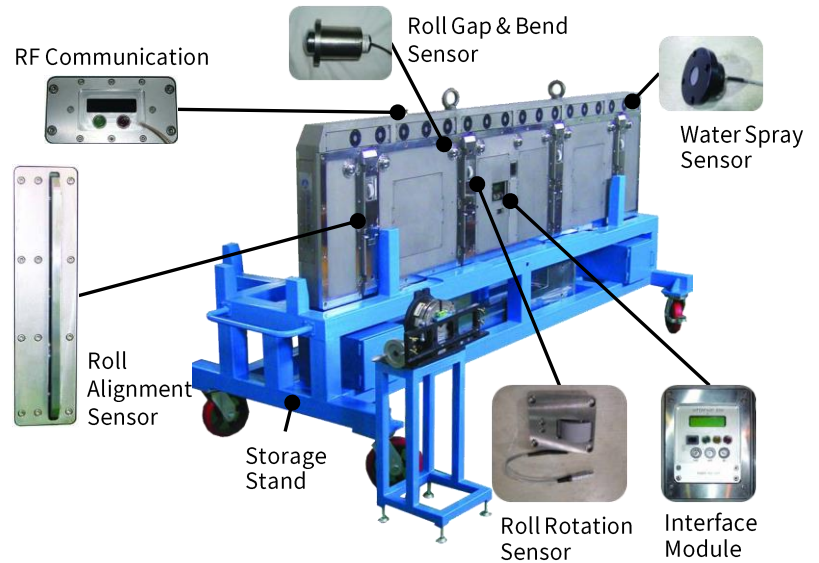

**MEASUREMENT OF ROLL GAP** can be done by collecting the signal from a pair of gap sensor installed at both sides of monitor frame which serves as the reference plane of measuring sensor with calibrated thickness. By using sampling rate considering gap sensor design and high speed data processing scheme, measuring accuracy is ensured regardless of variable dummy bar traveling speeds.

**MEASUREMENT OF ROLL BENDING/WEARING** can be done in two ways; (1) by measuring the distance to outer roll surface at different locations across the width direction (2) by measuring roll gap at multiple points through the circumference of circular rolls and comparing the deviation between the measured values.

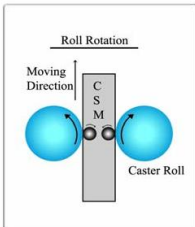
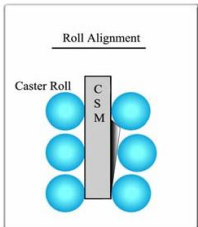

**MEASUREMENT OF ROLL ALIGNMENT** is done only for fixed side roll arrangements showing the magnitude of roll misplacement. By double checking misaligned angles of the target roll against the rolls placed on front and rear sides, the short comings of sequential measurements of the relative angle can be recovered.

**MEASUREMENT OF ROLL ROTATION** is determined as the slip ratio of rotation sensor wheels which contact the surface of the caster roll. If the roll bearing condition is very good as to rotate freely by dragging force of the anvil friction, no slip happens between the sensing wheel and roll as to generate no signal to the rotation sensor.

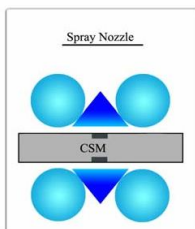
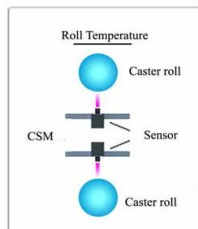

**MEASUREMENT OF ROLL TEMPERATURE** is done by non-contact type fast response ultrasonic sensors. Since the roll temperature is determined by the combined cooling efficiency of the water spray, roll and bearing cooling circuit, it can give very useful information for optimized scheduling of the maintenance and repair.

**MEASUREMENT OF SPRAY NOZZLE CONDITIONS** is done by highly sensitive pressure sensor. Arrayed spray sensors across the slab width check spray cooling intensity which is linearly dependent on impact pressure at monitor surface. For the clogging condition check of every spray nozzle, the sensor arrangements are designed to be at least a 1 to 1 match against overall spray nozzle locations.

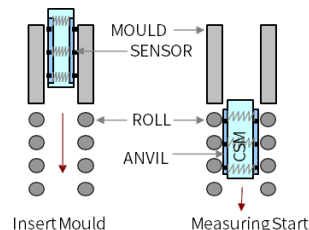
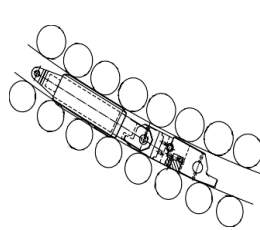
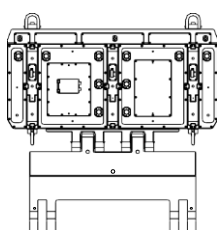
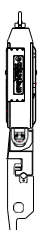

# EG Series Ladle Slide Gate System

## EG Ladle gate features

### Easy operation

- Automatic tensioning system

### Simple mechanism

- Simple and Easy assembly
- Reduced spare part & maintenance costs

### Robust structure design

- Increased safety in longer life of the slide gate

### Optimized refractories

- Increased refractory lifetime
- Lower operation cost

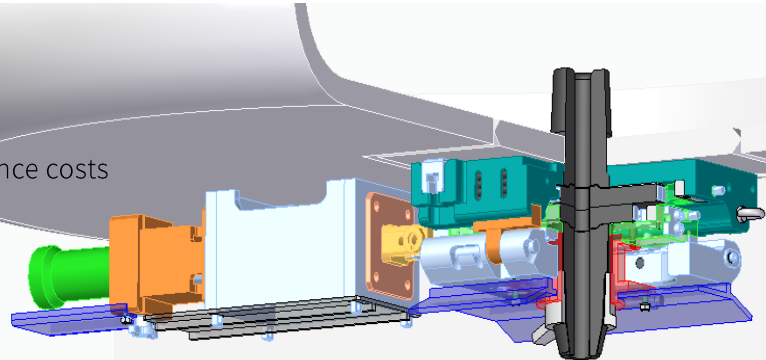

## EG Series technical data

Brand name	EG-150	EG-200	EG-230
Ladle capacity (ton)	~ 150 to	70 ~ 180 to	150 ~ 300 to
Maximum bore diameter	Ø80 mm	Ø100 mm	Ø110 mm
Sliding stroke	150mm	200mm	230mm
Weight (approx.)	650kg	750kg	850kg



## EG Gate main parts

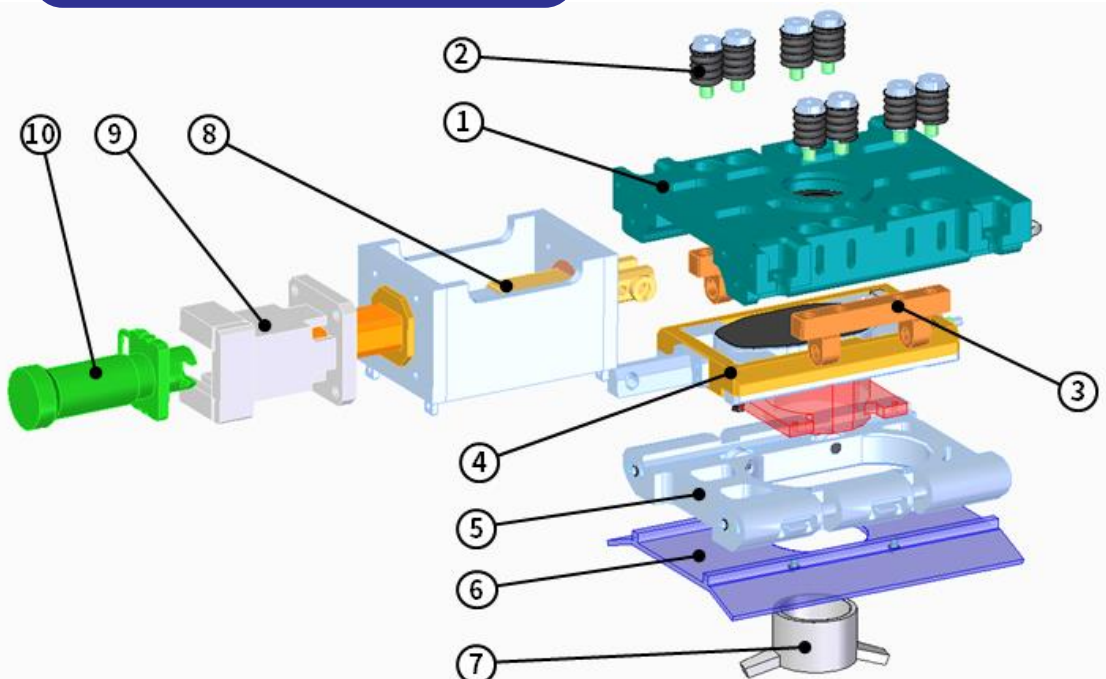

- ① Upside frame
- ② Coil spring
- ③ Spring support
- ④ Slide frame
- ⑤ Lower frame
- ⑥ Protection shield
- ⑦ Lower nozzle holder
- ⑧ Connecting rod
- ⑨ Actuator holder
- ⑩ Hydraulic cylinder

# PAQC Series Tube changer TSG System

## PAQC Tube changer TSG features

### Air tight housing

- Preventing air aspiration from TSG to mold
- Improved steel quality

### Tube quick change : within 1 sec.

- Increased sequence length & productivity

### Simple mechanism

- Simple and Easy assembly
- Reduced spare part & maintenance costs

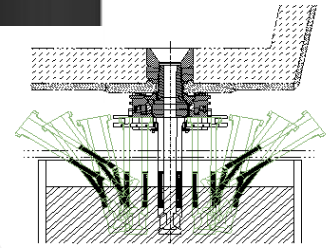
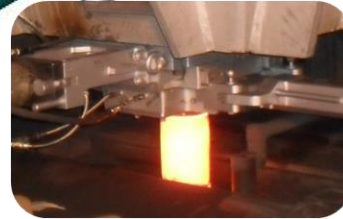

## PAQC Series technical data

Brand name	PAQC-90	PAQC-125
Max. bore diameter	Ø35 mm	Ø90 mm
Closing stroke	90 mm	125 mm
Weight (approx.)	250 kg	550 kg
Product application	BB / BL	Slab

## PAQC main parts

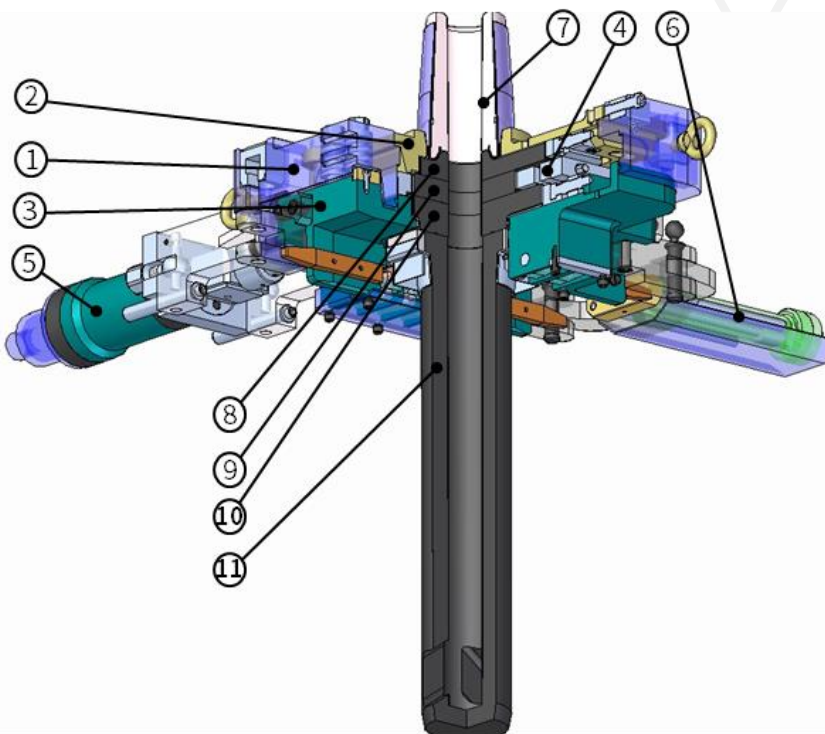

- ① Housing
- ② Upper cover
- ③ Lower housing
- ④ Slider
- ⑤ Hydraulic cylinder for slider
- ⑥ Hydraulic cylinder for tube changing
- ⑦ Upper nozzle
- ⑧ Upper plate
- ⑨ Middle plate
- ⑩ Lower plate
- ⑪ Tube (Submerged nozzle)

[www.mje.company](http://www.mje.company)

**HEAD OFFICE**

#501-1 HAKSAN TOWER B/D, 154, JUNGANG-RO, NAM-GU, POHANG-SI, GYEONGSANGBUK-DO, KOREA 37788

**SEOUL OFFICE**

#501, DAEJI B/D, 557, SAMSEONG-RO, GANGNAM-GU, SEOUL, KOREA 06155

**CONTACT US**

MOBILE. 82 10 6689 0108    EMAIL. sean\_kim@mje.company    [www.mje.company](http://www.mje.company)

 **MJE Co.,Ltd.**  
Steel & Engineering Company